



# Custom Clothing Size Guides

# SIZE GUIDE



## How to Measure

1. Lay your previous favourite garment flat on a table.
2. Use a tape measure and measure across the front of the chest under the armpits as shown (A).
3. Double the chest measurement to get the FullChest measurement.
4. Use a tape measure and measure from the highest point of the shoulder to the desired hemline as shown (B).
5. To measure hoodies, jackets, pants & shorts use the same method as whilst referring to the diagram at the specific garment.

**A** = Half Chest

**B** = Length

Please note sizing changes with different garments therefore determine the measurement in cms and compare it against the provided chart for that garment.

*E.g., A 120cm Full Chest measurement equals an XL*

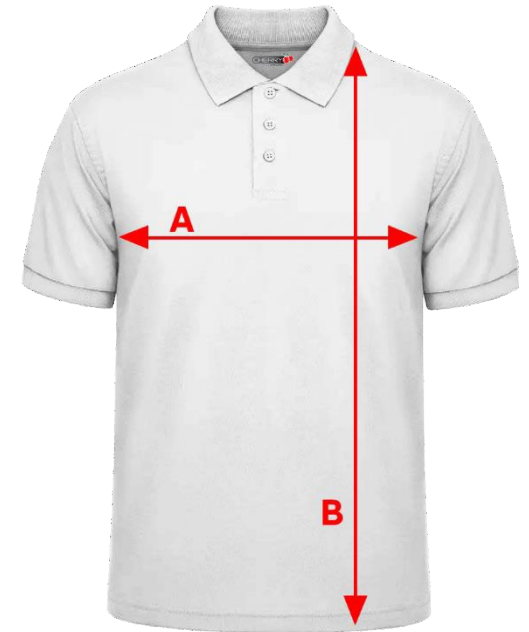

SIZE (cm):

Measurement	S	M	L	XL	2XL	3XL	4XL
Full Chest (Half Chest x2)	105	110	115	120	125	130	135
Length (Top shoulder point)	71	74	77	79.5	82	84.5	87

# POLO / T-SHIRT Size Guide



## Mens/Unisex

SIZE (cm):

Measurement	S	M	L	XL	2XL	3XL	4XL	5XL	7XL
Full Chest (Half Chest x2) (A)	105	110	115	120	125	130	135	140	150
Length (Top shoulder point) (B)	71	74	77	79.5	82	84.5	87	89.5	94.5

## Ladies

SIZE (cm):

Measurement	6	8	10	12	14	16	18	20	24
Full Chest (Half Chest x2) (A)	89	94	99	104	109	114	119	124	134
Length (Top shoulder point) (B)	59.5	62	64.5	67	69.5	72	74.5	77	82

## Kids

SIZE (cm):

Measurement	^04	^06	^08	^10	^12	^14	^16
Full Chest (Half Chest x2) (A)	72	77	82	87	92	97	102
Length (Top shoulder point) (B)	52	54.5	57	59.5	62	64.5	67

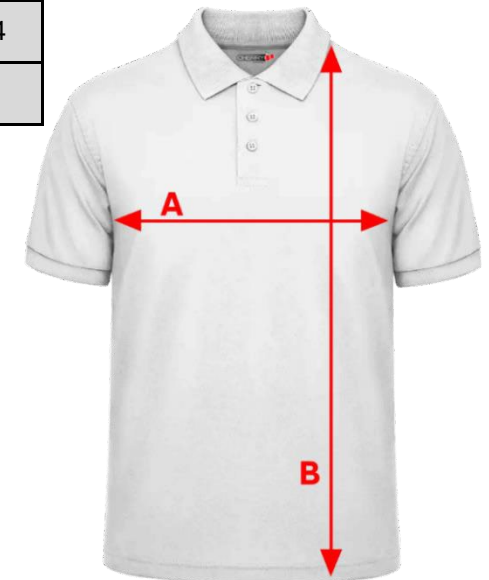

**Size Disclaimer:**

We make every effort to give accurate information regarding sizing and dimensions for our products in our size guides.

Please note that due to the nature of the manufacturing process, from time-to-time product sizing may vary slightly. Cherry Apparel is not responsible for sizing variations in the manufacturing process.

## SINGLET Size Guide



### Mens/Unisex

SIZE (cm):

Measurement	S	M	L	XL	2XL	3XL	5XL
Full Chest (Half Chest x2) (A)	102	107	112	117	122	127	137
Length (Top shoulder point) (B)	69	72	75	78	81	84	90

### Ladies

SIZE (cm):

Measurement	8	10	12	14	16	18	20
Full Chest (Half Chest x2) (A)	92	97	102	107	112	117	122
Length (Top shoulder point) (B)	64.5	67	69.5	72	73.5	75	76.5

### Kids

SIZE (cm):

Measurement	^06	^08	^10	^12	^14	^16
Full Chest (Half Chest x2) (A)	72	77	82	87	92	97
Length (Top shoulder point) (B)	51	54	57	60	63	66

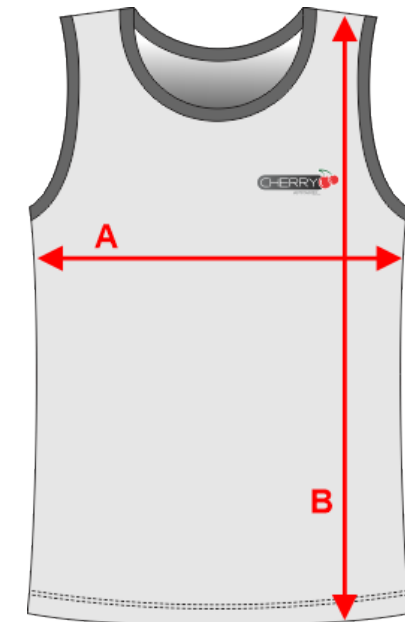

#### Size Disclaimer:

We make every effort to give accurate information regarding sizing and dimensions for our products in our size guides.

Please note that due to the nature of the manufacturing process, from time-to-time product sizing may vary slightly. Cherry Apparel is not responsible for sizing variations in the manufacturing process.

# HOODIE Size Guide



## Adults/Unisex

SIZE (cm):

Measurement	S	M	L	XL	2XL	3XL	4XL	5XL
Full Chest (Half Chest x2) (A)	112	117	122	127	132	137	142	147
Length (Top shoulder point) (B)	73	75	77	79	81	83	87	91

## Kids

SIZE (cm):

Measurement	4	6	8	10	12	14	16
Full Chest (Half Chest x2) (A)	82	86	90	94	98	102	106
Length (Top shoulder point) (B)	53	55	57	60	62	64	66

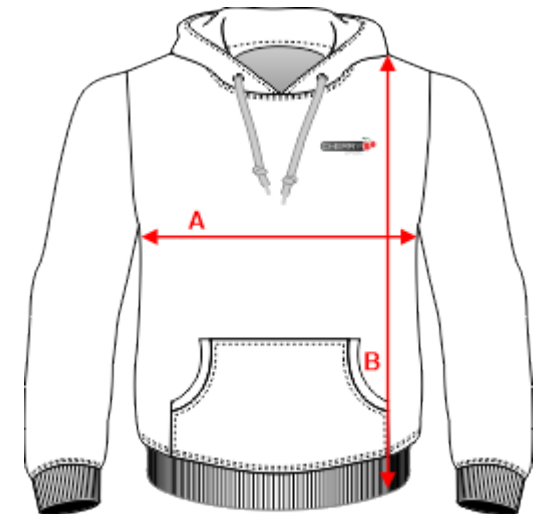

Size Disclaimer:

We make every effort to give accurate information regarding sizing and dimensions for our products in our size guides.

Please note that due to the nature of the manufacturing process, from time-to-time product sizing may vary slightly. Cherry Apparel is not responsible for sizing variations in the manufacturing process.



## SOFTSHELL JACKET Size Guide



### Mens/Unisex

SIZE (cm):

Measurement	XS	S	M	L	XL	2XL	3XL	5XL
Full Chest (Half Chest x2) (A)	110	115	120	125	130	135	140	150
Length (Top shoulder point) (B)	68.5	71	73.5	76	78.5	81	83.5	88.5

### Ladies

SIZE (cm):

Measurement	8	10	12	14	16	18
Full Chest (Half Chest x2) (A)	100	105	110	115	120	125
Length (Top shoulder point) (B)	66	68.5	71	73.5	76	78.5

### Kids

SIZE (cm):

Measurement	6	8	10	12	14	16
Full Chest (Half Chest x2) (A)	80	85	90	95	100	105
Length (Top shoulder point) (B)	50.5	54	57	60.5	63.5	66.5

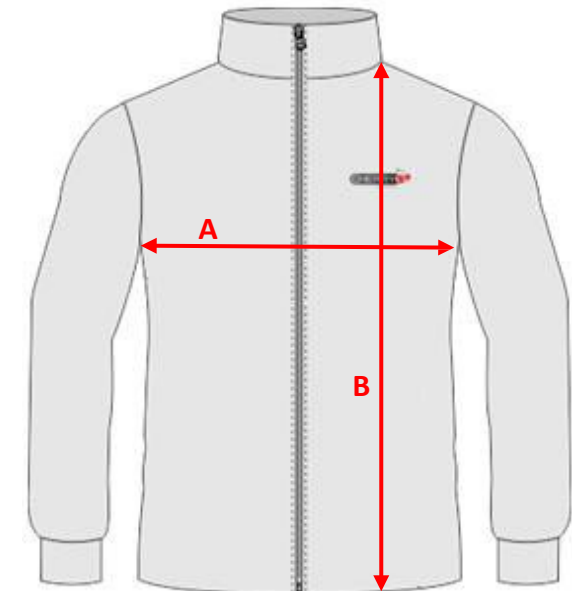

Size Disclaimer:

We make every effort to give accurate information regarding sizing and dimensions for our products in our size guides.

Please note that due to the nature of the manufacturing process, from time-to-time product sizing may vary slightly. Cherry Apparel is not responsible for sizing variations in the manufacturing process.

# CRICKET PANTS Size Guide



## Ladies

SIZE (cm):

Measurement	4	6	8	10	12	14	16	18	20	22
Full Waist (A)	57.6	61.3	65	68.7	72.5	76	80	83.5	87.2	91
Hip (B)	88	93	98	103	108	113	118	123	128	133
Length (Side) (D)	98.5	101	103.5	106	108.5	109.5	111	112.25	113.5	114.75

## Mens

SIZE (cm):

Measurement	S	M	L	XL	2XL	3XL
Full Waist (A)	68	71	74	77	80	83
Inner Leg (C)	70.5	72	73.5	74	74.5	75
Length (Side) (D)	103.5	106	108.5	109.5	111	112.25

## Kids

SIZE (cm):

Measurement	^08	^10	^12	^14	^16
Full Waist (A)	53	56	59	62	65
Inner Leg (C)	60	64	68	72	76
Length (Side) (D)	81	86	91	96	101

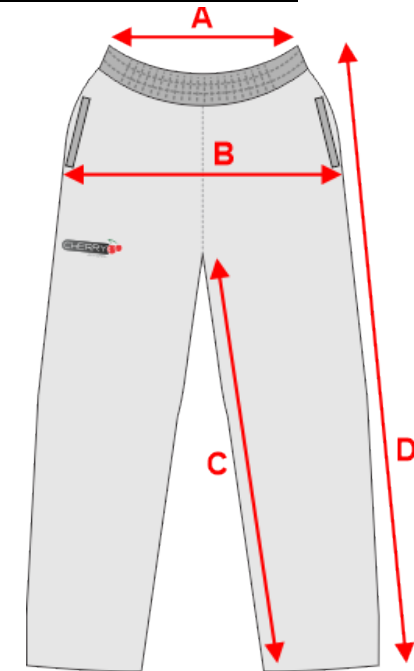

Hip (B) – Ladies Only

Size Disclaimer:

We make every effort to give accurate information regarding sizing and dimensions for our products in our size guides.

Please note that due to the nature of the manufacturing process, from time-to-time product sizing may vary slightly. Cherry Apparel is not responsible for sizing variations in the manufacturing process.

# LADIES CRICKET SHORTS Size Guide



## Ladies

SIZE (cm):

Measurement	8	10	12	14	16	18	20	22
Full Waist (A)	65	68.7	72.5	76	80	83.5	87.2	91
Length (Side) (B)	32	33	34	35	36	37	38	39
Crotch Front (C)	25	25	25	25.5	25.5	25.5	26	26
Crotch Back (D)	36	36	36	36.5	36.5	36.5	37	37
Back Length (E)	43	43.5	44	44.5	45	45.5	46	46.5
Hip (F)	98	103	108	113	118	123	128	133
Inner Leg (G)	14	14	15	15	16	16	17	17

FRONT

BACK

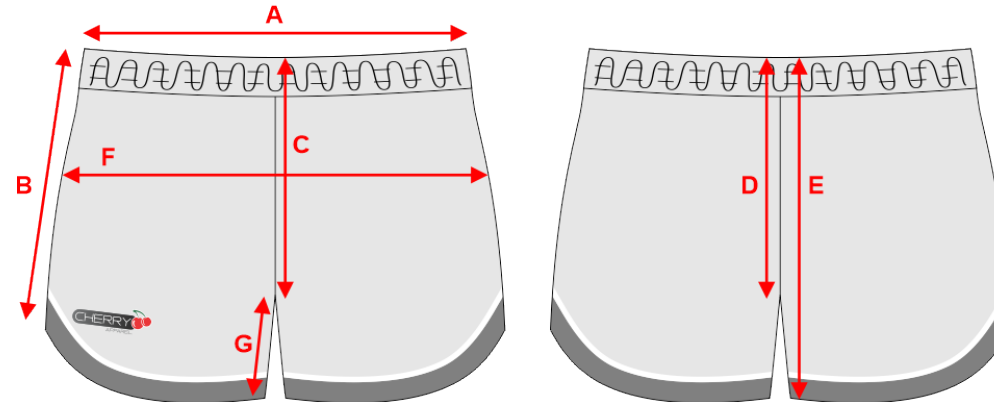

*Size Disclaimer:*

We make every effort to give accurate information regarding sizing and dimensions for our products in our size guides.

Please note that due to the nature of the manufacturing process, from time-to-time product sizing may vary slightly. Cherry Apparel is not responsible for sizing variations in the manufacturing process.



## PREMIUM SHORTS Size Guide



### Adults/Unisex

SIZE (cm):

Measurement	S	M	L	XL	2XL	3XL	5XL	7XL
Full Waist (A)	67	70	73	76	79	82	85	88
Length (Side) (C)	41	43	45	47	49	51	53	55

### Kids

SIZE (cm):

Measurement	^06	^08	^10	^12	^14	^16
Full Waist (A)	52	55	58	61	64	67
Length (Side) (C)	36	38	40	42	44	46



*Size Disclaimer:*

We make every effort to give accurate information regarding sizing and dimensions for our products in our size guides.

Please note that due to the nature of the manufacturing process, from time-to-time product sizing may vary slightly. Cherry Apparel is not responsible for sizing variations in the manufacturing process.

## SOCCER SHORTS Size Guide



### Mens

SIZE (cm):

Measurement	S	M	L	XL	2XL	3XL
Full Waist (A)	69	73	77	81	85	89
Length (Side) (B)	44	46	48	50	52	54

### Kids

SIZE (cm):

Measurement	^04	^06	^08	^10	^12	^14	^16
Full Waist (A)	49	52	55	58	61	64	67
Length (Side) (B)	32	34	36	38	40	42	44

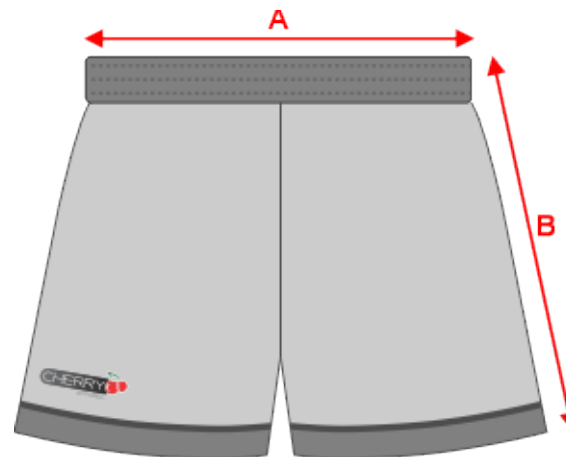

*Size Disclaimer:*

*We make every effort to give accurate information regarding sizing and dimensions for our products in our size guides.*

*Please note that due to the nature of the manufacturing process, from time-to-time product sizing may vary slightly. Cherry Apparel is not responsible for sizing variations in the manufacturing process.*

# SKORTS Size Guide



## Ladies

SIZE (cm):

Measurement	8	10	12	14	16	18	20	22
½ Waist (A)	34	36	38	40	42	44	46	48
Length (Side) (B)	37	39	40.5	42	43	44	45	46

## Girls

SIZE (cm):

Measurement	4	6	8	10	12	14
½ Waist (A)	25	27	28	29	30	32
Length (Side) (B)	24	27	29	31	33	35

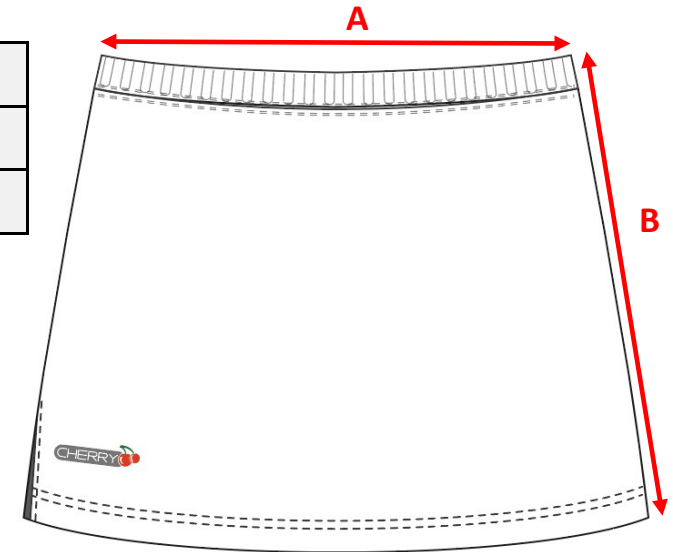

**Size Disclaimer:**

We make every effort to give accurate information regarding sizing and dimensions for our products in our size guides.

Please note that due to the nature of the manufacturing process, from time-to-time product sizing may vary slightly. Cherry Apparel is not responsible for sizing variations in the manufacturing process.

# NETBALL DRESS Size Guide



## Ladies

SIZE (cm):

Measurement	8	10	12	14	16	18	20	22
½ Chest (A)	42	45	48	50	52	55	59	62
½ Waist (B)	38	41	44	46	48	51	55	58
Full Length (C)	80	82	84	87	90	93	96	99

## Girls

SIZE (cm):

Measurement	Y6	Y8	Y10	Y12	Y14
½ Chest (A)	31	33	35	37	39
½ Waist (B)	28	29	30	32	35
Full Length (C)	70	72	74	76	78

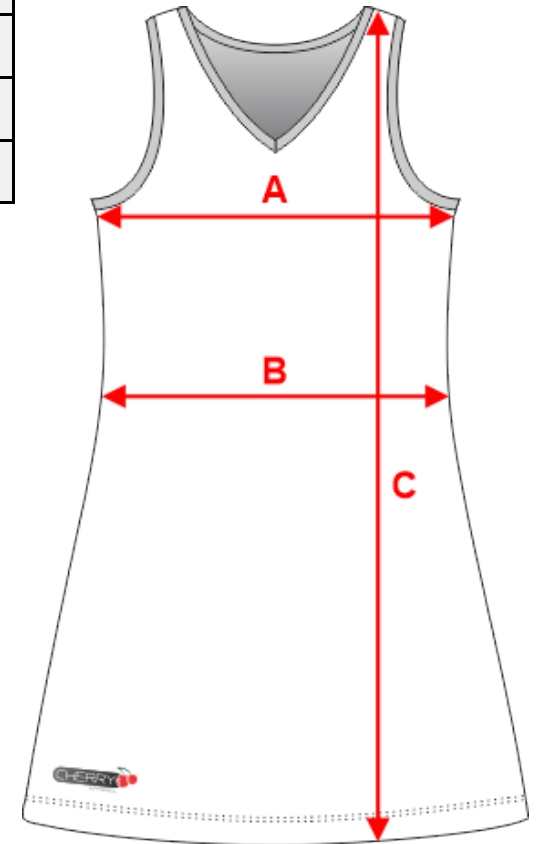

# CUSTOM SOCK Size Guide



SIZE (cm):

XXL : (57 X 29) cm XL : (54 X 27) cm L : (50 X 24) cm M : (45 X 21) cm S : (40 X 18) cm XS : (37 X 15) cm XXS : (34 X 14) cm

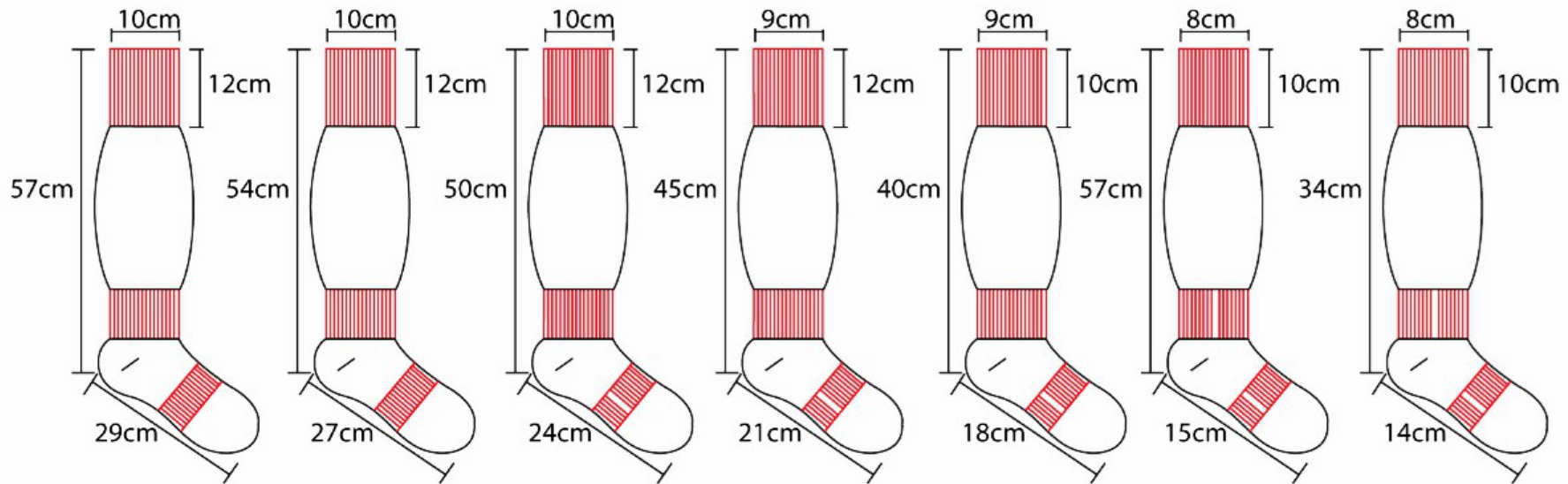

11-14

7-11

2-7

13-3

9-12